



PÓS-VENDA
TMA

Always a differential.

THE EVOLUTION OF POWER



SEE THIS MACHINE IN THE FIELD!



VTX 9040 SUGAR CANE WAGON

TMA sugar cane wagon stands out for its robustness and operational performance. Its structure is designed to support the most severe working conditions.

Some of its advantages are:

- ▶ The largest actual volume available in the 90 m³ cargo basket: approximately 45.000 kg.
- ▶ Shorter maintenance cycle.
- ▶ The smallest turning radius on the market.
- ▶ Load elevator with favorable angle for filling.
- ▶ Greater reach on the transport trailer, centralizing the load.
- ▶ Its volumetric capacity makes it possible to fill each semi-trailer of the truck tractor with a single supply (single load).

TECHNICAL SPECIFICATIONS

TOTAL WIDTH	4.240 mm
TOTAL LENGHT WITH REAR HITCH	14.140 mm
TOTAL HEIGHT	3.980 mm
LOAD HEIGHT	3.600 mm
TRANSSHIPMENT HEIGHT	4.700 mm
GAUGE	3.000 mm
VOLUME CAPACITY	90 m ³
HEAPED VOLUMETRIC CAPACITY	90 m ³ (estimated)
LOAD CAPACITY	45 t.
EQUIPAMENT TARE WEIGHT	20 t.
MINIMUM REQUIRED POWER	260 hp
HIGH-FLOTATION TIRES	600/55-26.5

EXCLUSIVE TMA HEPTA (7 AXLES) SUSPENSION

- ▶ 30° steering on the axles.
- ▶ Electronic system for selective blocking of directional axles.
- ▶ Tubeless brake system with double springs and 8" brake lining.
- ▶ Brakes available on 5 axles.
- ▶ 03 40L Air Reservoir.
- ▶ Relay valves.
- ▶ Quick exhaust valves.

ELECTRIC CIRCUIT

- ▶ Auxiliary LED headlights.
- ▶ Siren reverse gear horn.
- ▶ LED Flashlight lamp.
- ▶ 6-pin or standard tractor plugs.

HYDRAULIC CIRCUIT

- ▶ Hydraulic cylinder $\varnothing 6 \times \varnothing 4'' \times 2000$ mm.
- ▶ Safety valve approved to meet the NR 12 safety standard.
- ▶ Hydraulic hoses sized to meet the NR 12 safety standard.

HEADER

- ▶ Reinforced header with $\varnothing 100$ mm pinball coupling and fixing flange.
- ▶ Safety Chain.
- ▶ Support leg.

LOAD ELEVATOR

- ▶ Sturdy rectangular structure.
- ▶ Pulleys with treated and lubricated bushings.
- ▶ Bearing with special bushings, without need for lubrication.
- ▶ Safety pin with padlock for maintenance.

ELEVATOR EQUALIZER

- ▶ Synchronized lifting system, equalizes the ascent of the elevator.
- ▶ Overload positioning sensor in relation to the trailer.

LOAD TANK

- ▶ Produced with QDR tubes with higher moment of inertia and less weight.
- ▶ Expanded upper plate and plain baseboard for better drainage.

OPCIONAIS:

- ▶ WHEEL CALIBRATION SYSTEM ®.
- ▶ Monitoring kit with rear camera and pneumatic lens cleaning system.
- ▶ Electronic System for selective locking of directional axles.
- ▶ Radial tires.
- ▶ Proximity and position sensors.

THE WORLD'S LARGEST SUGAR CANE WAGON IS FROM TMA

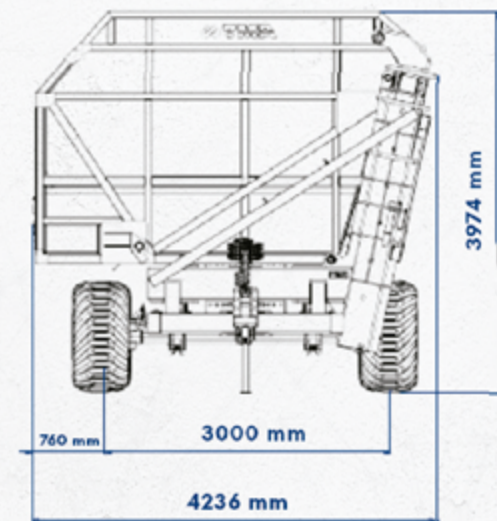
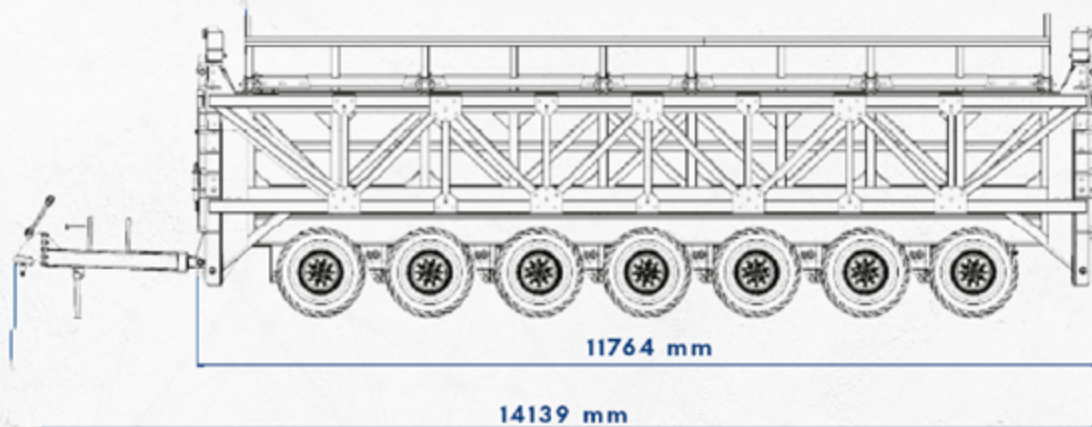

3100, Thomaz Alberto Whately Av.
Pg. Ind. Coronel Quito Junqueira
14075-380 - Ribeirão Preto/SP

Corporate TMA: +5516 3969.4933 | Technical Assistance WhatsApp: +5516 99772.5083

Business WhatsApp:
+5516 99629.7181

TMA WWW.TMAMAQUINAS.COM.BR



MADE IN
BRAZIL

